

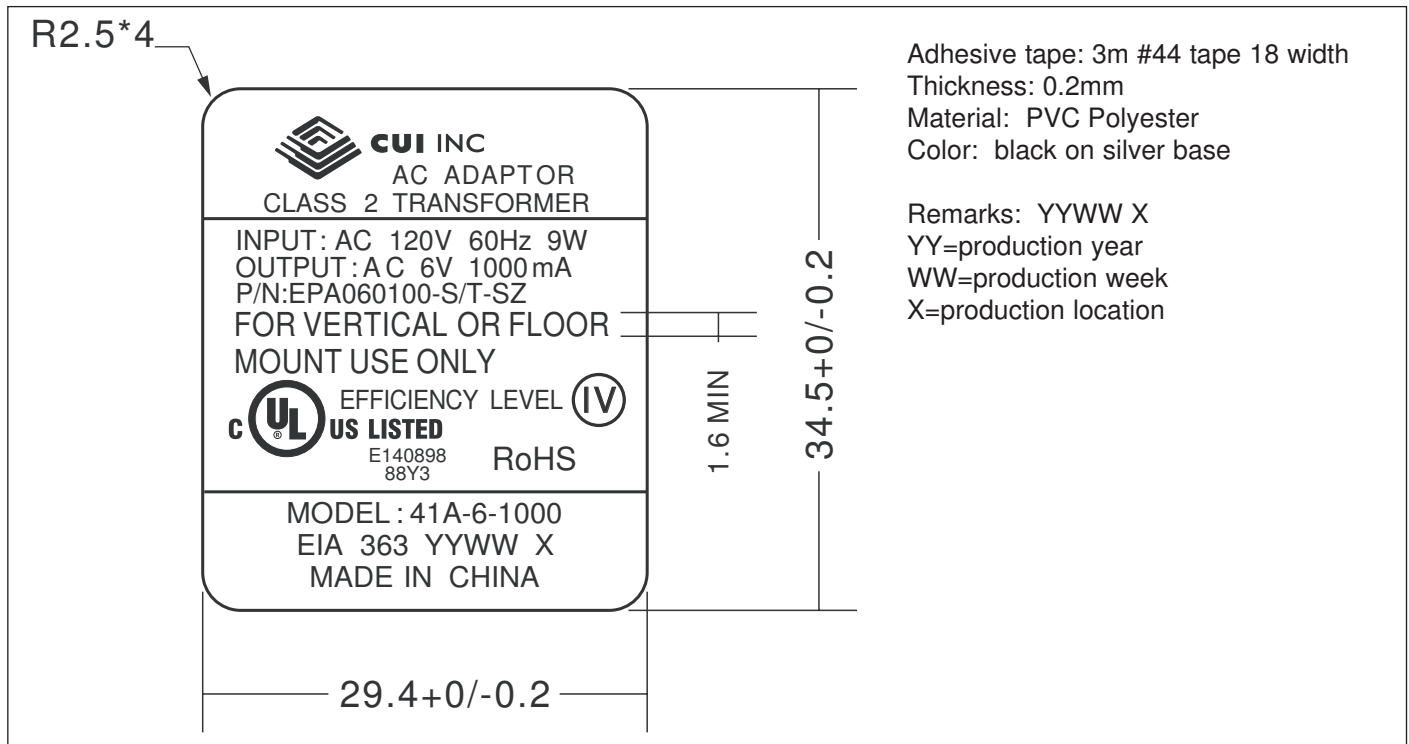

Specifications

Output voltage	6 V ac at 1000 mA	
Rated input voltage	120 V ac	
Primary rated voltage	120 V ac 60 Hz 9 W	
Primary exciting current	30 mA rms max.	
Secondary rated voltage & current	no load voltage (max.)	7.6 V ref
	full load voltage (1000 mA)	6 V \pm 5%
Temperature rise of primary winding (full load)	70°C max. using resistance method	
Insulation resistance	\geq 100 M Ohm at 500 V dc	
HI-POT test	from input to output for 1 min.	1240 V ac at 2 mA
	from input to output for 1 sec.	1600 V ac at 2 mA
	from primary to secondary winding for 1 sec.	1600 V ac at 2 mA
	from primary winding to core for 1 sec.	1600 V ac at 2 mA
	from secondary winding to core for 1 sec.	750 V ac at 2 mA
Safety standards	UL/cUL	
RoHS compliant	yes	
No load power consumption	0.5 W max.	
Efficiency	Energy Star Compliant - Efficiency Level IV	
Test conditions	Ambient temp	40°C \pm 2°C
	Humidity	90-95% 96 hours at Full Load
	Rated voltage	8 hours at full load
Adapter color	Case	black
	Cord	black



Label





Mechanical Drawing

Tolerance: ± 1

Weight 280 g

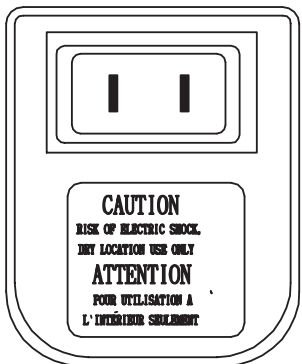
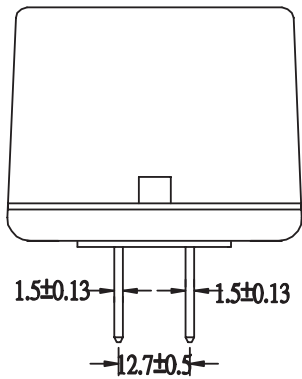
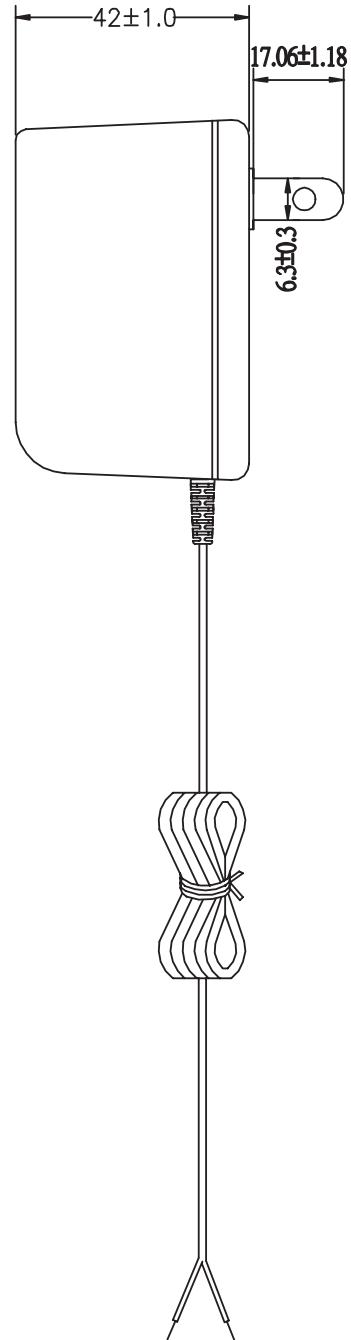
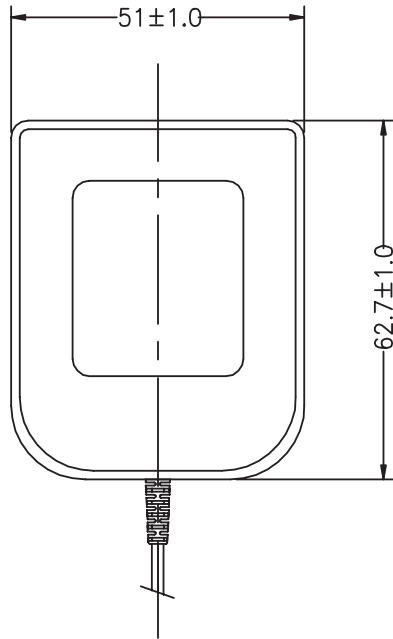



DC Cord

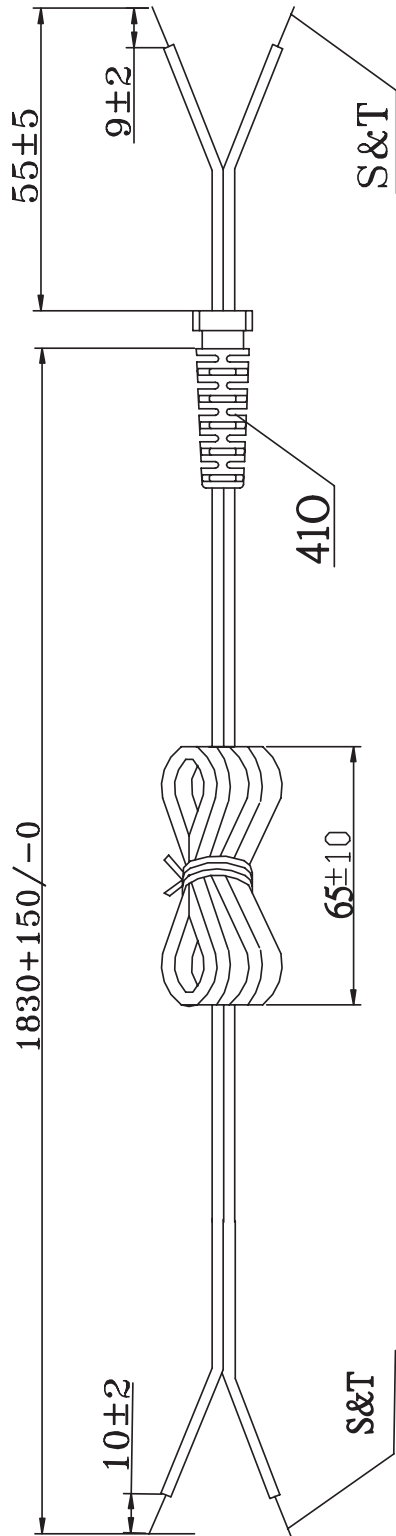

#22AWG X2C BLACK/WHITE WIRE BLACK WIRE IN NEGATIVE, BLACK/WHITE WIRE IN POSITIVE

WIRE OD: Ø1.8X3.6

VIBRATION TEST	Parameter request
	<ul style="list-style-type: none"> a. $\pm 60^\circ$ b. WEIGHT 200g c. 40 ROUND/MINUTE d. OVER 1000 COUNT MIN

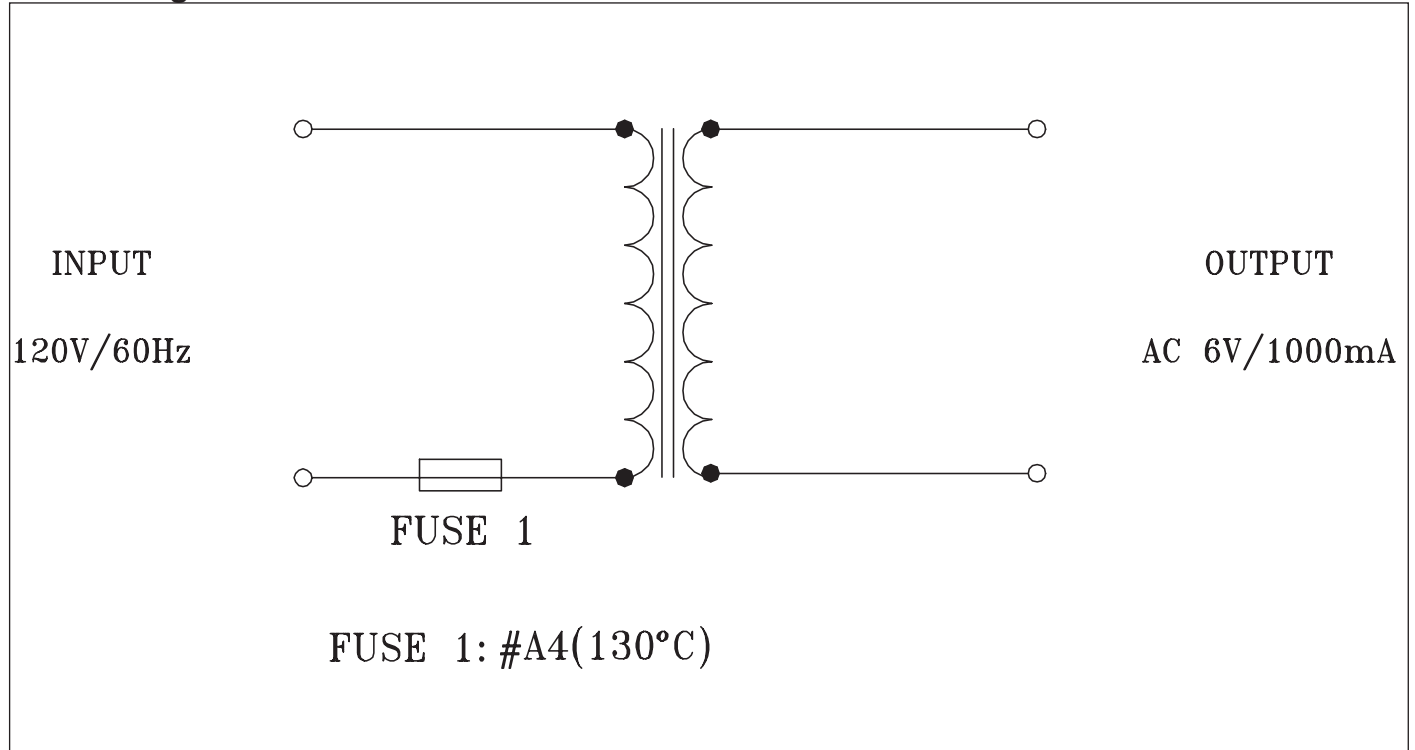
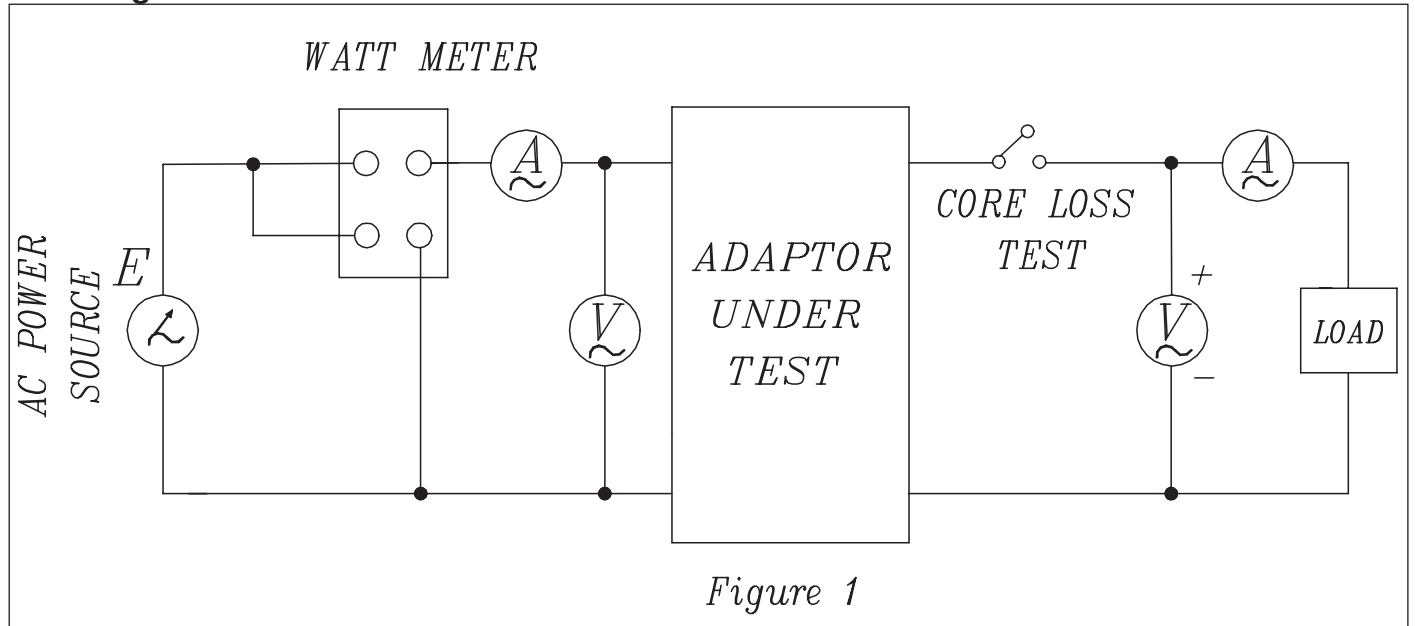
Circuit Diagrams

Test Diagram

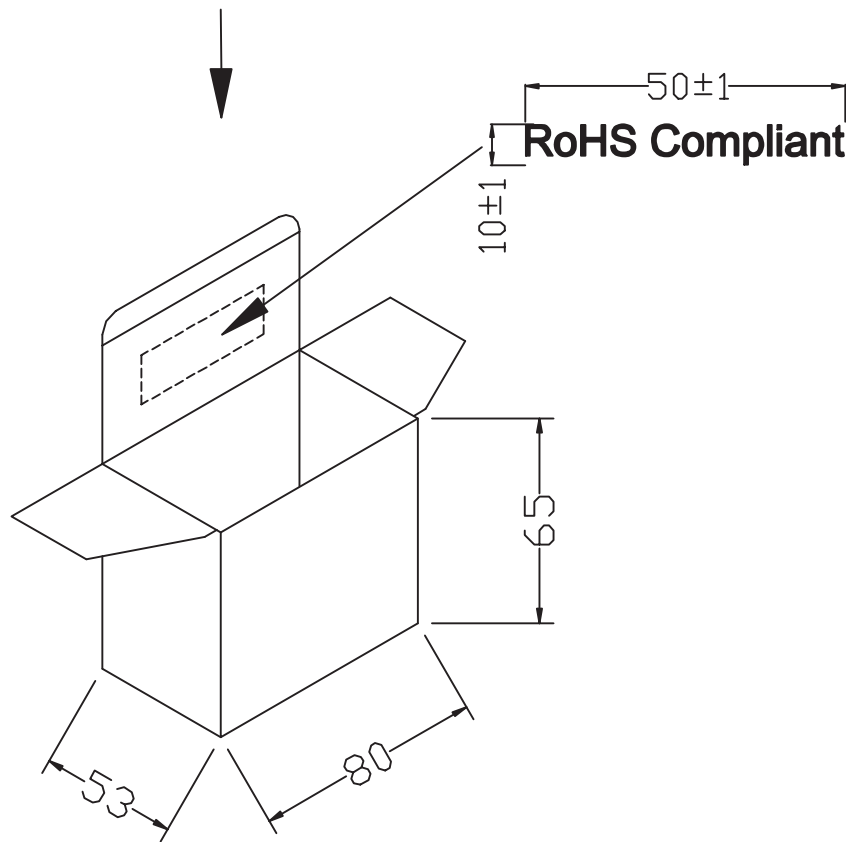
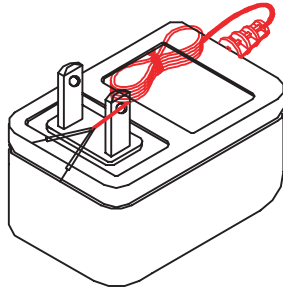

Individual Packaging

Tolerance: ± 1





Packaging

Tolerance: +7/-0

OUTSIDE CARTON:A=B(6mm)

INSIDE CARTON:A-B(3mm)

CARTON SIZE: 350X345X190mm

Q'TY: 60pcs(20x3x1)

N.W:16.8KGS

G.W:17.8KGS

G.W:18.8KGS

